

PlusHP
SINGLE-SPEED PUMPS



Jandy[®]

POWERFUL, EFFICIENT PERFORMANCE



PLUSHP
SINGLE-SPEED PUMPS

High performance in a mid-size body

PlusHP offers high head performance, power, and efficiency in a mid-sized body, making it suitable for a wide range of applications.

- Large Strainer Basket**
 The PlusHP strainer basket is 40% larger than the leading competitor, allowing it to maintain performance while under debris load.
- Ergonomic Design**
 Features ergonomic tool free drain plugs, cam-lock lids with alignment indicators, and a convenient carry handle.
- Unions Included**
 2" x 2 1/2" unions are included for fast and reliable installation and maintenance with no hidden costs.

PERFORMANCE

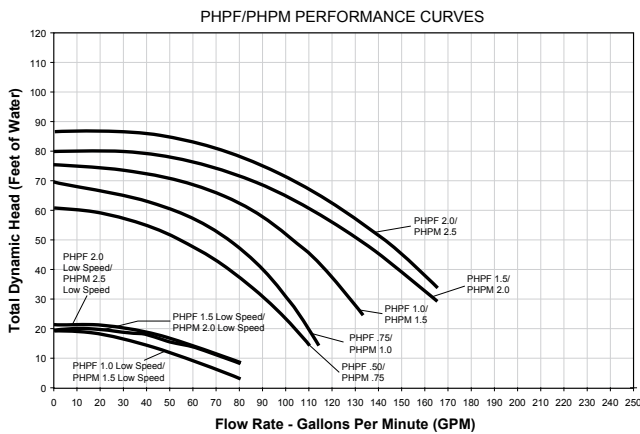

Residential PlusHP Pumps, DOE Compliant

Part No.	THP	WEF	Voltage	Amps	Recommended Pipe Size ¹	Carton Weight	Length A
PHPF.50 PHPM.75	0.95	3.6/3.8	230/115	5.4/10.8	1 1/2-2"	40.4 lbs.	26 1/2"

Residential PlusHP Pumps, Not DOE Compliant²

Part No.	THP	WEF	Voltage	Amps	Recommended Pipe Size ¹	Carton Weight	Length A
PHPF.75 PHPM1.0	1.24	-	230/115	7.1/14.2	2 -2 1/2"	41.8 lbs.	26 1/2"
PHPF1.0 PHPM1.5	1.65	-	230/115	8.0/16.0	2 -2 1/2"	43.3 lbs.	26 7/8"
PHPF1.5 PHPM2.0	2.25	-	230/115	11.2/22.4	2 -2 1/2"	54.6 lbs.	28 1/2"
PHPF2.0 PHPM2.5	2.60	-	230	11.5	2 -2 1/2"	49.3 lbs.	27 1/2"
PHPF1.0-2 PHPM1.5-2	1.65	-	230	7.2/3.0	2 -2 1/2"	48.7 lbs.	27 1/2"
PHPF1.5-2 PHPM2.0-2	2.21	-	230	10.0/3.5	2 -2 1/2"	52.9 lbs.	28"
PHPF2.0-2 PHPM2.5-2	2.60	-	230	11.0/4.0	2 -2 1/2"	62.3 lbs.	28 1/2"

DIMENSIONS

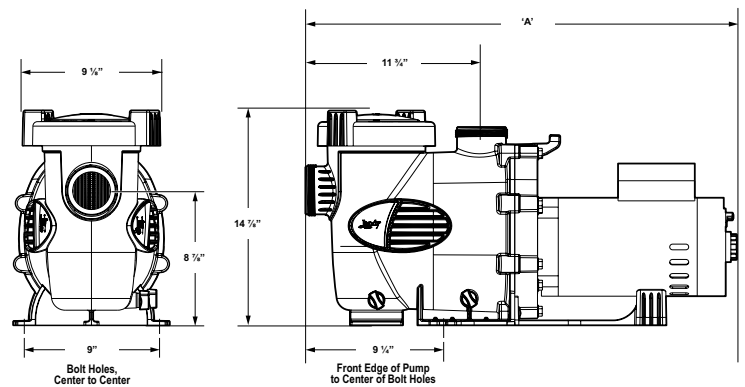

¹ Always follow local building and safety codes for power requirements and guidelines.

² Pumps not meeting DOE compliance standards have ceased manufacturing on or before July 18, 2021. Specifications are being provided for historical reference.

Jandy.com | 1.800.822.7933